

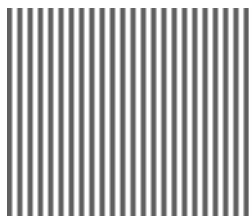

IR-BHT Series

- IR-BAT1 (Type)
- IR-BAT2 (• Type)
- IR-BATS (• Type)



INSTRUCTIONS

CHINO

/ /

IR-BA

Trouble

CE Marking

()

89/336EEC, 92/31/EEC(amendment), 93/68/EEC(amendment)

()

EN61326+A1 Class A, EN61326+A1 Annex A1



• •



1.

가

2.

가 가

3.

가

1

가

Label

)

•

•

, Gas(),

Mark ()



가
OFF

Symbol Mark



가



가



가 Title



	가			
Gas	가 Gas, Gas Gas			⊘
				⊘
	가			⊘
				⊘

1. (: 95%)

			()	/	
Type	IR-BAT1A	0~300	100ms	Ø40/500mm	8~14µm
	IR-BAT1B	0~600			
Type	IR-BAT2A	0~300	100ms	Ø5/80mm	
Type	IR-BATSA	0~300	100ms	Ø40/1000mm	
	IR-BATSB	0~600			

			()	/	
Type	IR-BAT1M	0~300	50ms	Ø40/500mm	8~14µm
	IR-BAT1P	0~600			
Type	IR-BAT2M	0~300	50ms	Ø5/80mm	
Type	IR-BATSM	0~300	50ms	Ø40/1000mm	
	IR-BATSP	0~600			

2.

FA Sensor,
Compact Card Size

CE Marking

1 DC 1 Cable 30m

3.

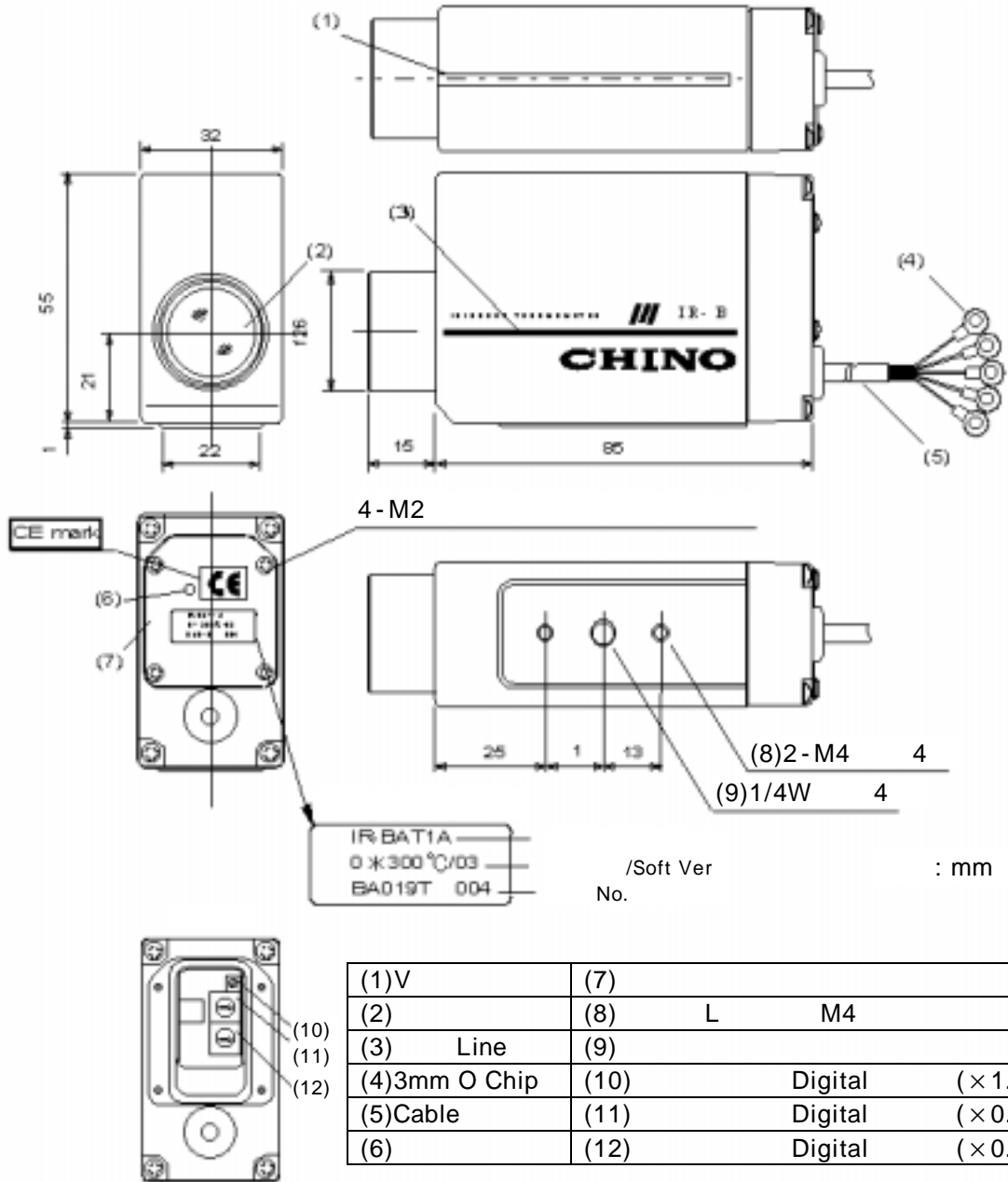

4.

4.1

• • • 9

8 M4



- 가 0~50
- Noise가
- 가 Gas, Gas Gas

4.2



9 가 8 M4 1.5

Type
IR-BAT1A, IR-BAT1B
Type
IR-BAT1M, IR-BAT1P

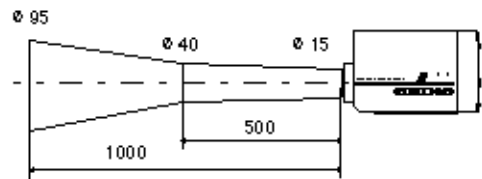

IR-BAT2A
IR-BAT2M

Type
Type

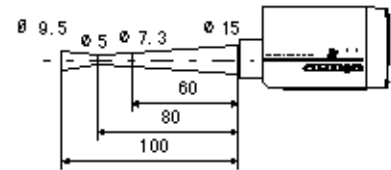

IR-BATSA, IR-BATSB
IR-BATSM, IR-BATASP

Type
Type

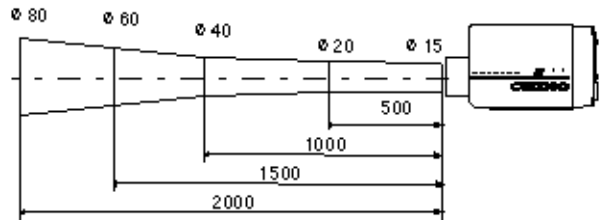

14.3

1 V , 3 Line



가
가 가

5.



5 Cable 4 3mm O Chip

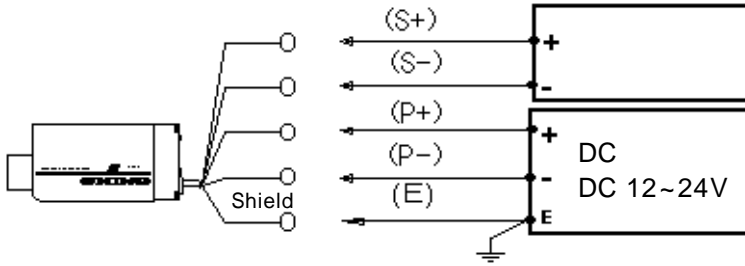

	Analog (+)	DC 4~20mA
	Analog (-)	280
	(+)	DC 24V(±10%)
	(-)	60mA
Shield		



• OFF



• DC 24V(±10%),60mA
• Lead Short

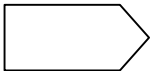

• Lead , ,
• IR-GBHA1, IR-GC1, IR-GBG2

6.

1)

가

6

2)

Digital

Analog

10 11 12



• 가 10 11 12
• Digital 가
• (1) 가
• (2) 가



• 가

Digital

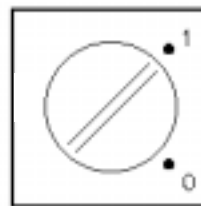
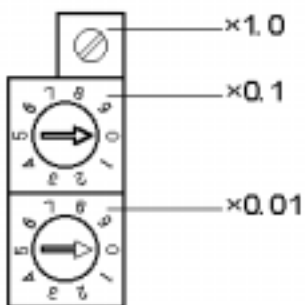

「1」 「0」

7.

- 1) 2 가 Blower . Blower 가



가 ' ' .

- 2)
- 3) Lead

8. Trouble Shooting

가

	Lead

Lead	Lead
Noise가	Noise
Digital	
	가
가	

9.



9.1

- 1) 0~50
- 2) ,
- 3) ,
- 4) Gas Gas

9.2

5 Cable Noise , Relay Line, Line 가 Duct
Noise가 Line

9.3

- 1) ± 10%

2) ON/OFF Noise가

9.4 Warning Up

11. Accessaris

- IR-ZBML

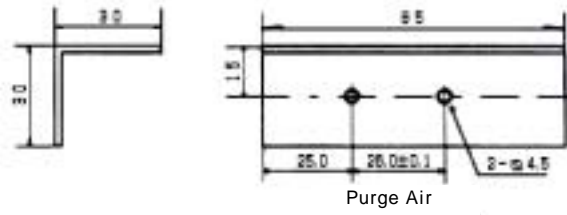

- Case IR-ZBCSH

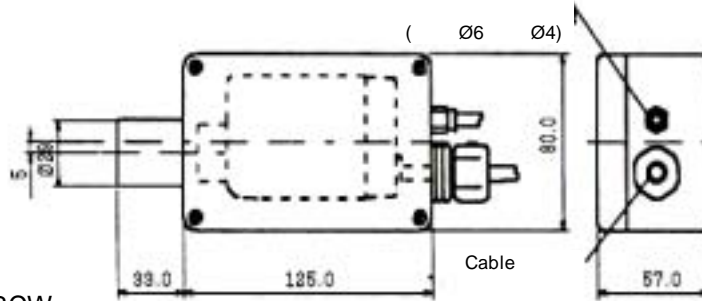

- Case IR-ZBCW

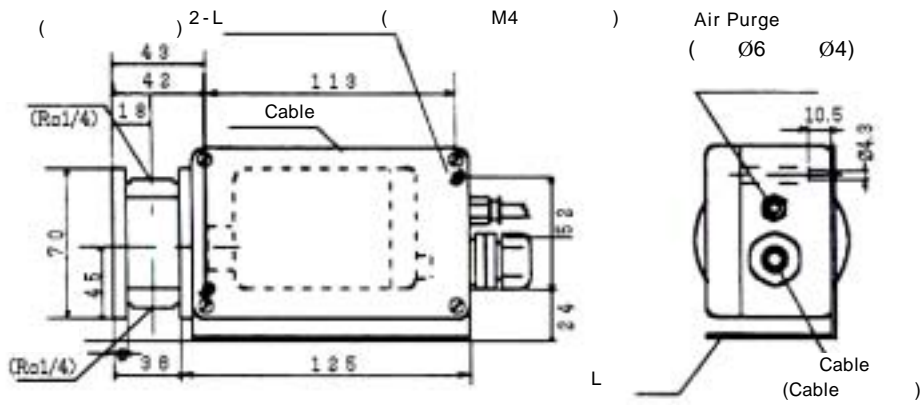

- Sanitary Case IR-ZBCA

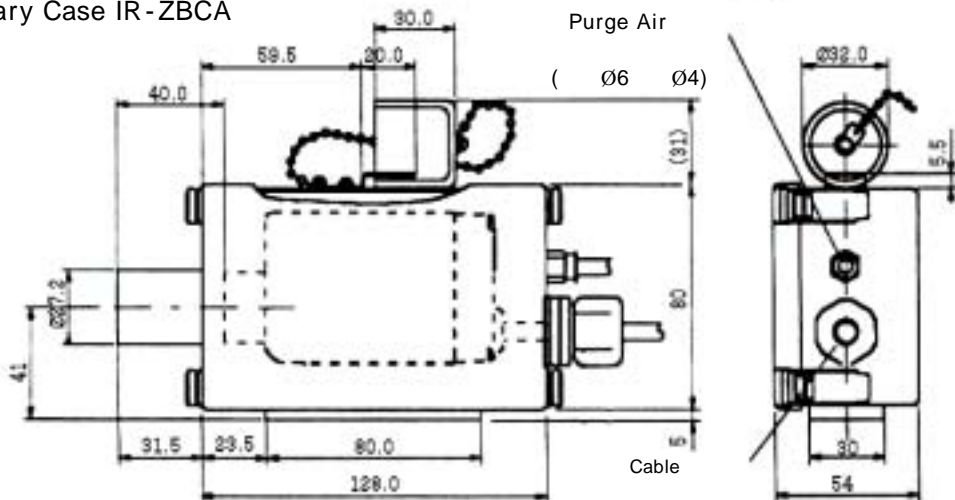

: mm

12.

[]	, / 「1. • 」
	Thermopile
	8~14 μ m
	300 : ± 3 , 300 : $\pm 1.0\%$ (, =1, 23 ± 5 , 35~75%RH)
	Ge
	=1.99~0.1(Digital)
Analog	DC 4~20mA (280)
	0~50
	DC 12~24V($\pm 10\%$)
	60mA
Cable	2m(30m) CE Mark Cable 200m
Case	
	220g

[]	IR-BAT1A, IR-BAT2A, IR-BATSA IR-BAT1M, IR-BAT2M, IR-BATSM	IR-BAT1B, IR-BATSB IR-BAT1P, IR-BATSP
	300	~600
	0.2 (JIS)	0.5 (JIS)
	± 10 (EMC Test)	
	± 0.2	± 0.3

CHINO

CHINO

☎ 445-813

296-1

TEL : (031)379 - 3700

FAX : (031)379 - 3777

http : // www.chinokorea.com

e-mail : webmaster@chinokorea.com

()